

# Air powered oil cleaner unit

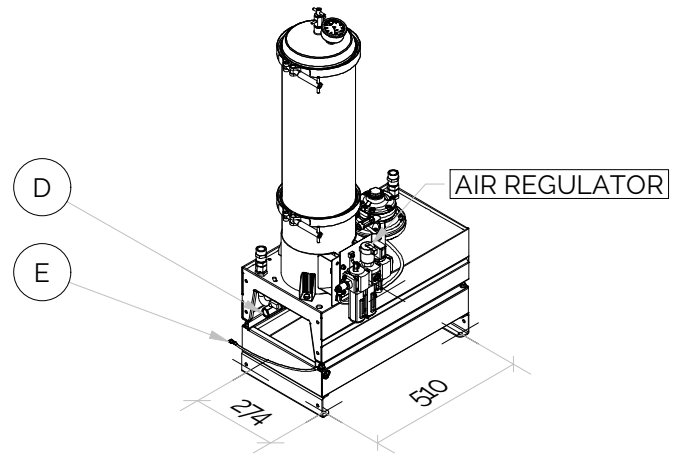
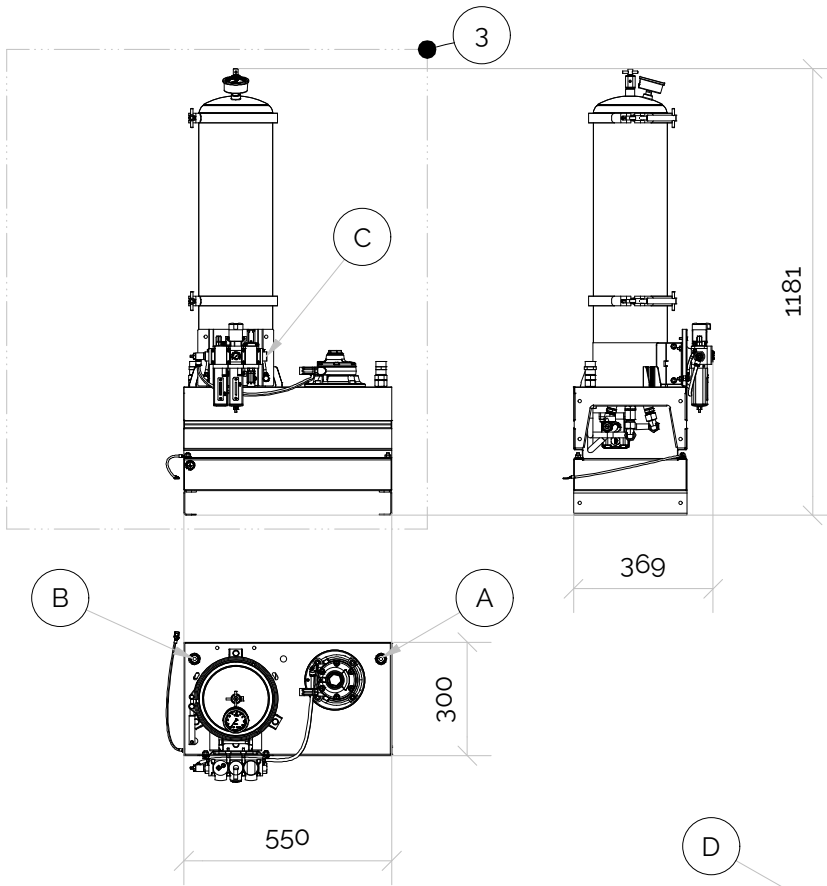

## Air driven oil cleaner unit

Can be configured as a unit with 1 to 6 inserts  
**ATEX CAT. II 2G Ex h IIC T4 Gb Tamb +1°C to 40°C**  
 Normal working oil pressure 0.1 to 6 Bar  
 Max. oil max. oil pressure 7

### Removes;

- \* Varnish & mitigates varnish in system
- \* Particles, abrasives & wear
- \* Moisture, water & salts
- \* Bacterias (No chemicals)

Flow is cSt dependent of fluid, cleanliness level.  
 Typical flow 1 lpm per insert @ ISOVG32

©2019, 2020 Delta-Xero All Rights Reserved

## PARTS LIST

ITEM	QTY	PART NUMBER	DESCRIPTION	MATERIAL
1	1	DX1001TGP-NNNNN12N	SINGLE AIR POWERED OIL CLEANER UNIT	SS316L
2	1	DX1002TGP-NNNNN12N	DOUBLE AIR POWERED OIL CLEANER UNIT	SS316L
3	1	DX1003TGP-NNNNN12N	TRIPLE AIR POWERED OIL CLEANER UNIT	SS316L
4	1	DX1004TGP-NNNNN12N	FOUR DOUBLE AIR POWERED OIL CLEANER UNIT	SS316L
6	1	DX1006TGP-NNNNN12N	SIX DOUBLE AIR POWERED OIL CLEANER UNIT	SS316L
A	1		FLUID SUCTION INLET PORT TO PUMP, G1/2"	SS316L
B	1		FLUID RETURN DISCHARGE PORT TO OIL RESERVOIR, G1/2"	SS316L
C	1		AIR SUPPLY TO MOTOR, G1/4"	SS316L
D	1		DRAIN BALL VALVE G3/8" OR G1/2"	SS316L
E	1		EARTH GROUNDING	Cu

Designed by ME	Checked by	Approved by	Date	Date 09.01.2020
-------------------	------------	-------------	------	--------------------

	TRIPLE AIR POWERED OIL CLEANER		
	DX1003TGP-NNNNN12N	Edition A2019	Sheet 1 / 1